



The Original MultiTable Hand Crank Standing Desk by MultiTable



DIMENSIONS AND SPECS:

BASE

Colors

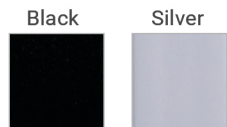

Materials

Powder coated, rolled stamped steel

Dimensions

Height Adjustable Range:	27.5" - 47"
Height Adjustable Range w/ Top:	28.25" - 47.75"
Width Adjustable Range:	39.5" - 55.5"
Top Support Depth:	23.25"
Foot Depth:	29.5"

Weight Limit/Capacity

130 lbs.

Warranty

5-Year Limited

DESK TOP

Colors



Materials

High Quality Wilsonart® or Prism Thermally Fused Laminate Top (TFL) w/ Matching PVC Edgebanding

Sizes

Small Desk Top:	24" x 40" x 3/4"
Medium Desk Top:	24" x 48" x 3/4"
Large Desk Top:	29" x 57" x 3/4"
Extra Large Desk Top:	29" x 72" x 3/4"
Custom Desk Tops:	Min. 24" x 40" x 3/4" Max. 36" x 72" x 3/4"

Wheel Kit*

Colors: Black and Silver

Casters: 2" (2 Locking and 2 Free Spinning)

The Original ModTable Hand Crank Standing Desk is our most popular height adjustable standing desk. Environmentally friendly with its manually operated turning handle that raises and lowers the desk 1 inch every two turns, this stand up desk gives you the chance to burn even more calories during your workday. MultiTable is proud to offer a manual standing desk with unparalleled performance, durability and quality. Not to mention its sleek, contemporary style will fit flawlessly in any professional environment.

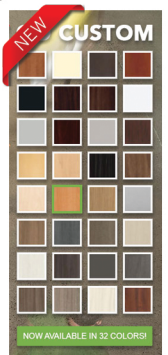



The Original MultiTable Hand Crank Standing Desk Frame by MultiTable



DIMENSIONS AND RANGE:

Front View

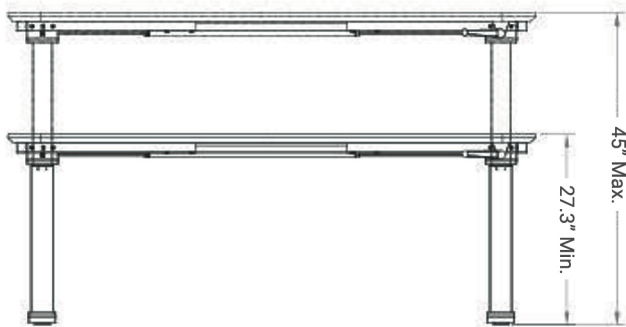

Top View

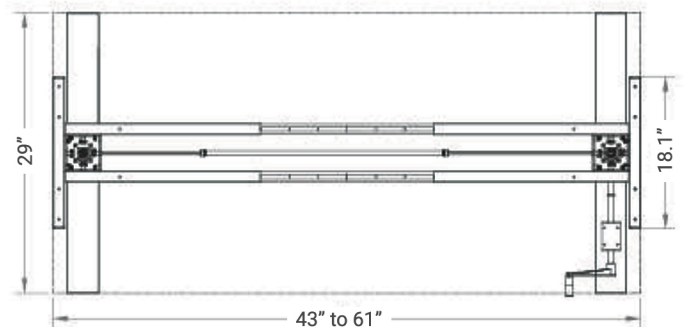

Colors

Black

Silver



Features

- ▶ Environmentally friendly with its manually operated turning handle that raises and lowers the desk with ease
- ▶ Width adjustable from 43" to 61" to accommodate most table top sizes
- ▶ Raises and lowers from 27.3 inches to 45 inches
- ▶ Innovative smooth spindle mechanism quickly raises and lowers base with ease at 4.5 turns per inch
- ▶ Fully customizable by adding high quality MultiTable® Desk Tops and ergonomic accessories
- ▶ Crafted from rolled stamped steel for superior strength and stability with a 133 pound capacity
- ▶ Offers a fine powder coat finish for maximum durability
- ▶ Includes a 5-year limited warranty and 30-day no risk return guarantee

The MultiTable Hand Crank Standing Desk Frame allows for users without access to power to work in the healthy and production standing position. The hand-crank frame is cordless, so it eliminates hanging or tangled frame cords. The design and construction process results in a highly sleek and durable finish with superior wear characteristics. And, this powerless adjustable height desk frame includes our MultiTable warranty, guarantee, and our highly-rated customer support for years to come.